



KIMMCO

KUWAIT INSULATING MATERIAL
MANUFACTURING CO. S.A.K.(Closed)

ISO 9001, ISO 14001
& OHSAS 18001 CERTIFIED

CE



BUILDING ROLL (KBR)

LIGHT WEIGHT, NO SAGGING NOR SETTLING

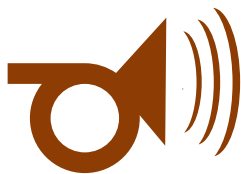

MANUFACTURED
UNDER LICENCE OF
ISOVER
SAINT-GOBAIN

www.kimmcoinsulation.com
www.alghanim.com

A subsidiary of
Alghanim
INDUSTRIES

BUILDING ROLL (KBR)



APPLICATIONS

For thermal and/or acoustic insulations of all buildings walls and roofs.

DESCRIPTION

KIMMCO building rolls are manufactured from stable glass fibers bonded with thermosetting resins. They are light in weight, strong, resilient and easy to handle.

FACINGS

KIMMCO building rolls are available unfaced or with a variety of facings to suit the applications: white vinyl, FSK, metallized polyester, kraft paper and glass tissue.

STANDARD DIMENSIONS

Thickness mm	Width m	Length m
25	0.4, 0.6, 1.0, 1.2	10 to 45
40	„	according
50	„	to the
75	„	thickness
100	„	& density

Non standard sizes may be available

NOMINAL DENSITY

KBR	kg/m ³	Lbs/ft ³
10	10	0.625
12	12	0.750
16	16	1
18	18	1.125
20	20	1.250
24	24	1.5

Other densities available

PERFORMANCES

WORKING TEMPERATURE

Fibre	230 °C
FSK	100 °C
Vinyl	80 °C
Metallized polyester	80 °C

PERMANENCE

Dimensionally stable under varying conditions of temperature and humidity, rot proof, odourless, non-hygroscopic and will not sustain vermin or fungus.

Longer life due to no sag and settling.

THERMAL CONDUCTIVITY

Thermal conductivity according to BS 874, ASTM C 177, 518; ISO 8301, 8302 or DIN 52612 are described in tables below:

MEAN TEMPERATURE °C	THERMAL CONDUCTIVITY IN W/m.K FOR THE FOLLOWING DENSITIES IN kg/m ³					
	10	12	16	18	20	24
0	0.038	0.036	0.034	0.033	0.032	0.031
10	0.040	0.038	0.036	0.035	0.034	0.032
25	0.044	0.041	0.039	0.038	0.036	0.035
50	0.055	0.048	0.044	0.043	0.041	0.039
75	0.064	0.059	0.051	0.048	0.046	0.043
100	0.074	0.065	0.057	0.053	0.051	0.047

THICKNESS mm	THERMAL RESISTANCE (m ² .K/W) AT 25°C MEAN TEMP.					
	KBR 10	KBR 12	KBR 16	KBR 18	KBR 20	KBR 24
25	0.568	0.610	0.641	0.658	0.694	0.714
40	0.909	0.976	1.026	1.053	1.111	1.143
50	1.136	1.220	1.282	1.316	1.389	1.429
75	1.705	1.829	1.923	1.974	2.083	2.143
90	2.045	2.195	2.308	2.368	2.500	2.571
100	2.273	2.439	2.564	2.632	2.778	2.857
125	2.841	3.049	3.205	3.289	3.472	3.571
150	3.409	3.659	3.846	3.947	4.167	4.286

MEAN TEMPERATURE °F	THERMAL CONDUCTIVITY IN Btu.in/ft ² .h.°F FOR THE FOLLOWING DENSITIES IN Lbs/ft ³					
	0.625	0.750	1	1.125	1.250	1.500
32	0.26	0.25	0.23	0.23	0.22	0.21
50	0.28	0.27	0.25	0.24	0.23	0.22
77	0.31	0.29	0.27	0.26	0.25	0.24
122	0.38	0.34	0.31	0.30	0.28	0.27
167	0.45	0.41	0.35	0.34	0.32	0.30
212	0.51	0.45	0.40	0.37	0.36	0.33

THICKNESS inch	THERMAL RESISTANCE (ft ² .h.F/Btu) AT 77 °F MEAN TEMP.					
	KBR 10	KBR 12	KBR 16	KBR 18	KBR 20	KBR 24
1	3.226	3.448	3.704	3.846	4.000	4.167
1.5	4.839	5.172	5.556	5.769	6.000	6.250
2	6.452	6.897	7.407	7.692	8.000	8.333
3	9.677	10.345	11.111	11.538	12.000	12.500
3.5	11.290	12.069	12.963	13.462	14.000	14.583
4	12.903	13.793	14.815	15.385	16.000	16.667
5	16.129	17.241	18.519	19.231	20.000	20.833
6	19.355	20.690	22.222	23.077	24.000	25.000

These are typical values subject to normal manufacturing and testing variances.

FIRE SAFETY

Base fibre are non-combustible when tested in accordance with BS 476 (Part 4), ASTM E 84, 136. Glass reinforced aluminum/kraft laminate facing (FSK) are U.L. classified as follows:

Flame spread : Not over 25
Smoke developed : Not over 50

Vinyl facing are U.L. classified as following:

Flame spread : 25
Smoke developed : 80 - 105

MOISTURE ABSORPTION

Less than 1% by volume when tested in accordance with BS 2972 or 6676, ASTM C 1104. KIMMCO building rolls do not absorb moisture from the ambient air nor water by capillary attraction. Only water under pressure can enter the insulation products, but that will quickly dry out owing to the material's open cell structure.

FSK faced building rolls comply with ASTM E 96 desiccant method. Permeance not to exceed 0.02 perms (Federal Standard HH-B-100B type 1).

Vinyl faced building rolls comply with ASTM E 96 desiccant method. Permeance not to exceed 1.0 perm.

NON TOXIC

KIMMCO BUILDING ROLL IS NOT HAZARDOUS TO HEALTH (See KIMMCO MSDS)

ACOUSTICS

ASTM C 423 - Mounting A as per ASTM E 795

PRODUCT		Absorption coefficient at the octave frequencies HZ						
Type	Thickness mm	125	250	500	1000	2000	4000	NRC
KBR 12	25	0.10	0.27	0.45	0.61	0.80	0.80	0.55
	50	0.20	0.52	0.71	0.86	0.95	0.80	0.75
	100	0.60	0.85	1.05	1.05	1.00	1.00	1.05
KBR 18	25	0.05	0.18	0.30	0.70	0.81	0.84	0.55
	50	0.20	0.51	0.72	0.80	0.88	0.88	0.80
	75	0.30	0.80	0.95	0.95	0.95	0.95	0.90
KBR 24	25	0.08	0.30	0.50	0.80	0.80	0.81	0.65
	50	0.22	0.57	0.87	1.00	0.98	1.00	0.90

These are typical values subject to normal manufacturing and testing variances.

CONFORMITY TO STANDARDS

KIMMCO building rolls comply with the following standards:

AMERICAN STANDARDS

ASTM C 167, 168, 177, 423, 518, 553, 653, 665 § 13.8 & 13.9, 686, 991, 1045, 1101/1101M, 1104/1104M, 1136 (types 1&2), 1335; E 84, 96, 136, 336, 795

UL 723

F.S. HH-B-100B (Type1), HH-I-521F, HH-I-558B

NFPA 255

NAIMA Standards

ASHARE 90.1 requirements

BRITISH STANDARDS

BS 476 (parts 4, 6 & 7), 874, 2972, 3533, 6676 (part 1)

GERMAN STANDARDS

DIN 18165, 52612

ISO

354, 8301, 8302, 9229, 9291

TYPICAL FIXING DETAILS

Wall construction of light weight metal sheeted buildings are frequently uninsulated, leading to extremely uncomfortable working conditions or excessive cooling requirements. KIMMCO building roll can be fitted to new and existing buildings to alleviate these problems.

NEW CONSTRUCTION

KIMMCO building roll is fixed at the head of the wall and allowed to drape down the length. The insulation roll may be fixed to sheeting rails with the faced side to the inside of the building if no lining sheets are to be used or alternatively by trapping the insulation between external and internal

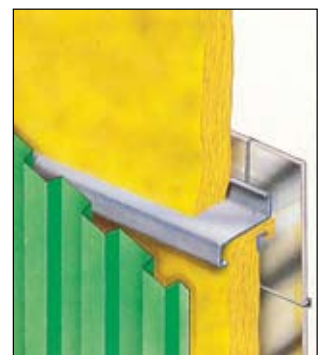

sheeting. Spacer bars of non compressible material should be used to prevent undue crushing of the insulation.

EXISTING BUILDINGS

KIMMCO building roll may be installed from within existing buildings by using a "T" bar suspension grille and liner sheets, the insulation can be cut to suit the size of lining sheet and fixed to the back of the sheet with adhesive or mechanical fasteners. The lining is then installed in the grid system in the normal manner.

As an alternative to the above, timber packing strips may be cut to suit the sheeting rails and screwed in place, fix the building roll at the head of the wall by screws into the timber packer with a steel strip placed on top of the insulation directly over the packer. Repeat as required at other sheeting rail locations, ensuring that the building roll are closely butted to each other with the edge flanges overlapping.

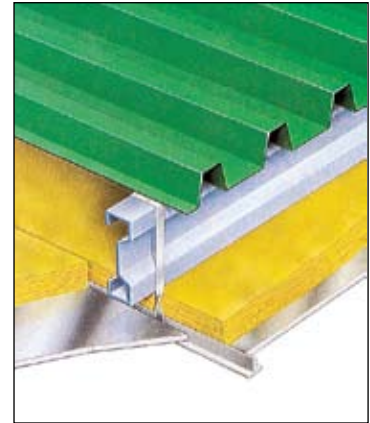
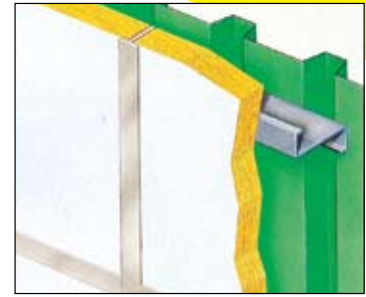

OVER PURLIN APPLICATION

Fix end of building roll faced side down, at ridge and allow to unroll to eaves. At eaves, roll should be cut and pulled taut. Each subsequent roll should be overlapped or butted to avoid gaps.

Packing strips, equal in thickness to the insulation, should be placed along the line of each purlin and fixed through the roofliner to the purlin below. This avoids undue compression of the insulation.

The roof cladding should be carried out in conjunction with the insulation work to avoid accidental damage. Fixing should be through the crown profile of the roofing sheet and down through the spacer to the purlin below.

Weathering sheets should be fitted as insulation, work progresses in order to avoid unnecessary damage to the insulation. Holes for hook bolts sealed against water penetration.

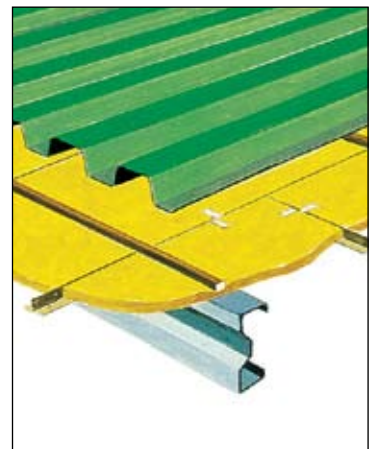

UNDER PURLIN APPLICATION

After application of roof covering, the internal lining and insulation can be carried out using a framework of light metal "T" sections suspended from the purlins by straps or hangers.

a) Cut building roll to size and lay on lining board. To assist in handling, the insulation may be adhered or stapled to the lining board. Erect lining board and insulation within the metal "T" grid securing as required.

b) Alternatively, the insulation can be applied from rolls initially secured at the ridge and allowed to unroll progressively towards the eave in conjunction with the application of lining boards. It is important that the adjacent layers of insulation are sufficiently overlapped to prevent heat loss or gain.

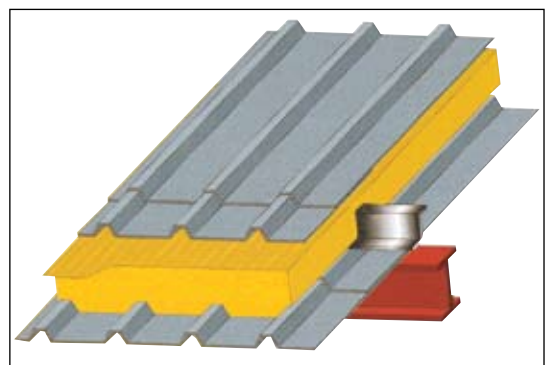

SANDWICH CONSTRUCTION

Roofs which incorporate double sheeting can be easily insulated with KIMMCO building roll due to its flexible nature. After initial fixing of the inner or lining sheeting, KIMMCO building roll should be fitted by unrolling from ridge to eave, ensuring that each subsequent roll overlaps or butts the preceding roll to eliminate gaps and maintain the effective insulation values desired. Fit spacers in the form of timber battens or proprietary profiled strips or other compression resistant materials on top of the insulation directly over the purlins to avoid crushing the insulation when the external weathering sheet is fitted.

DEMOUNTABLE PARTITIONS

Generally, factory assembled with metal or plasterboard facings. The addition of KIMMCO building roll to the partition void reduces the level of sound transmissions.

“A” PURPOSE BUILT LIGHT WEIGHT PARTITIONS

Due to the problems of load and the usual involvement of wet trades, heavy block partitions are commonly being replaced by purpose built light weight partitions. With careful design and construction, these partitions can provide adequate levels of sound transmission reduction.

Partitions should be constructed with as little mechanical linkage as possible, studs should be staggered to avoid direct transmission paths, with the insulation fitted or woven between them.

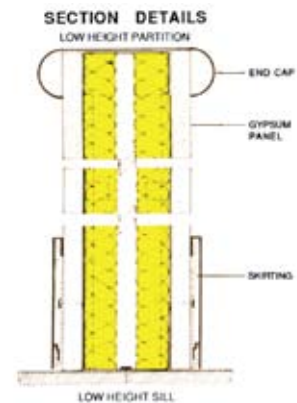

“B” SOUND ABSORPTION TREATMENT

In areas where sound absorption is required, KIMMCO building roll can be used to line the walls, behind a decorative or functional facing which will permit the passage of sound waves to the glass wool behind, thereby reducing the amount of sound reflected back. This type of treatment is commonly used in open plan offices, auditoriums, sports halls, sound studios, multi-purpose school halls and industrial areas.

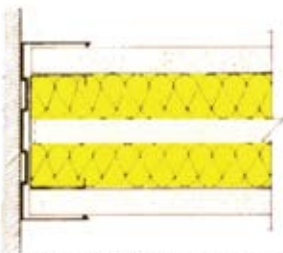

FULL / LOW HT. STARTER OR END PANEL

The insulation should be fitted directly against the wall surface, between timber battens. A surface treatment of perforated hard board or sheet metal can be fixed to the timber battens. The area of perforation should be no less than 10% for most common treatments, though a 33% perforation is preferable, as this gives an optimum amount of absorption. Should a more decorative treatment be required, a good quality curtain grade hessian or other decorative fabric can be applied.

ACOUSTIC INSULATION OF EXISTING CEILINGS

Building roll as overlay to new or existing ceilings to improve “R” value and acoustic performance.

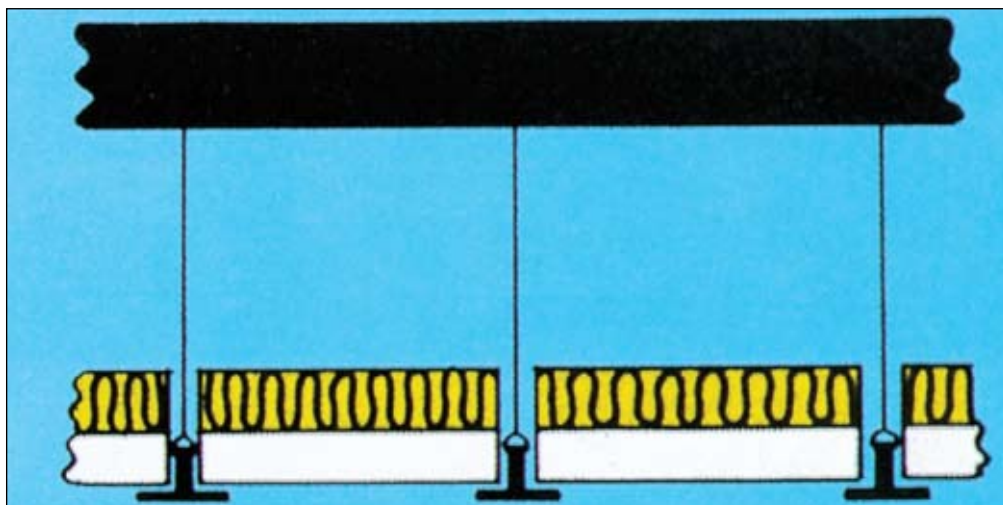



Underwriters Laboratories Inc.®



KUWAIT INSULATING MATERIAL MFG CO
 MICHEL C LUCE
 (OFF WAEBA RD BEHIND MINA ABDULLAH
 POLICE STATION NEAR KIRBY BLDGS PLANT)
 PO BOX 24609
 SAFAT KUWAIT

Your most recent listing is shown below. Please review this information and report any inaccuracies to the UL Engineering staff member who handled your Assignment.

BKNV March 28, 1994
 Batts and Blankets
 KUWAIT INSULATING MATERIAL MFG CO , SAFAT R9703 (N)
 KUWAIT

Glass fiber batts and blankets with and without facings on one surface.
 The following products are eligible to bear the Laboratories Classification Marking incorporating the designation "FHC 25/50" instead of the individual Surface Burning Characteristic values for flame spread and smoke developed:

	Basic Blanket	Foil-Scrim-Kraft Facing	Vinyl Film Facing	Aluminum Foil Facing
Flame spread	15	15	25	15
Smoke developed	0	0	80-105	0

(OFF WAEBA RD BEHIND MINA ABDULLAH POLICE STATION NEAR KIRBY BLDGS PLANT) PO BOX 24609

LOOK FOR CLASSIFICATION MARKING ON PRODUCT

170704001 H875 Underwriters Laboratories Inc.® A11/0086048
 116

For information on placing an order for UL Listing Cards in a 3 x 5 inch card format, please refer to the enclosed ordering information.

UNDERWRITERS LABORATORIES INC.

A not-for-profit organization dedicated to public safety and committed to quality service

333 Pfingsten Road
 Northbrook, Illinois 60062-2096, USA
 708/272-8800
 Telex: 6502543343
 FAX No. (708) 272-8128

1285 Wall Whitman Road
 Melville, L.I., New York 11747-3081, USA
 516/271-8200
 Telex No. 6852015
 FAX No. (516) 271-8259

1855 Scott Blvd.
 Santa Clara, California 95050-4169, USA
 408/985-2400
 FAX No. (408) 298-3256

12 Laboratory Drive
 P.O. Box 13995
 Research Triangle Park,
 North Carolina 27709-3995, USA
 919/549-1400
 Telex No. 4937926
 FAX No. (919) 549-1542

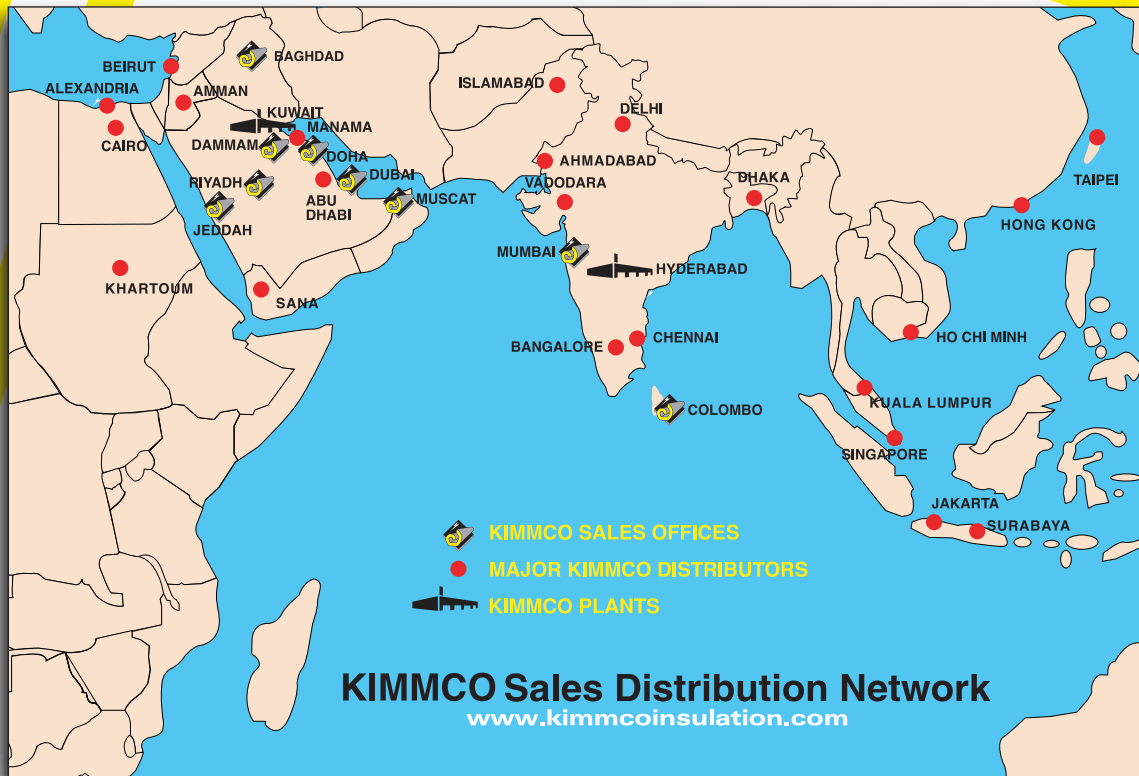

Customer Services

P.O. Box: 10042 Shuaiba, 65451 Kuwait
 Phone : (00965) 2 326 2020 Ext. 5339, 5340
 Fax : (00965) 2 326 1251, 2 326 2027
 Email : kimcsd@alghanim.com

Kuwait

P.O. Box: 24609 Safat, 13107 Kuwait
 Phone : (00965) 2 473 4439, 2 473 4467,
 2 471 0711, 2 474 7096
 Fax : (00965) 2 473 4538, 2 473 9789
 Email : kusales@alghanim.com

Exports

P.O. Box: 10042 Shuaiba, 65451 Kuwait
 Phone : (00965) 2 326 2020 Ext. 5335, 5337
 Fax : (00965) 2 326 1251, 2 326 2027
 Email : kimexp@alghanim.com

Saudi Arabia - Riyadh

P.O. Box: 63577 Riyadh, 11526 Saudi Arabia
 Phone : (009661) 476 3334
 Fax : (009661) 476 5731
 Email : kirbyriyadh@zajil.net

Technical Services

P.O. Box: 10042 Shuaiba, 65451 Kuwait
 Phone : (00965) 2 326 2020 Ext. 5310, 5311
 Fax : (00965) 2 326 1251, 2 326 2027
 Email : kimtech@alghanim.com

Saudi Arabia - Jeddah

P.O. Box: 402 Jeddah, 21411 Saudi Arabia
 Phone : (009662) 663 1829, 663 1702, 663 1536
 663 1361 (Ext. 207, 208, 209)
 Fax: : (009662) 661 3620
 Email : ngkimmcojed@zajil.net

Qatar / Oman / Bahrain

P.O. Box: 7943 Doha, Qatar
 Phone : (00974) 4995075 / 4995077
 Fax : (00974) 4995088
 Email : kimmcoqatar@qatar.net.qa

Saudi Arabia - Dammam

P.O. Box: 2788 Dammam, 31461 Saudi Arabia
 Phone : (009663) 833 1678, 832 6488
 Fax : (009663) 832 6477
 Email : kimmcoem@sahara.com.sa

United Arab Emirates - Dubai

P.O.Box: 9207, Dubai, United Arab Emirates.
 Tel : (00971) 4 2967660 / 50 6529132
 Fax : (00971) 4 2967550
 Email : kimmco@emirates.net.ae

STORAGE: To avoid moisture in the building construction, KIMMCO insulation products which are stored outside must be kept dry. KIMMCO is not liable for the damage resulting from an improper utilization to TEL products manufactured or marketed by KIMMCO. KIMMCO products are manufactured under license of Isover Saint Gobain – France, using the latest technological developments of the famous TEL process. Kuwait Insulating Material Manufacturing Company (KIMMCO) reserves the right to alter product specifications without prior notice as part of its policy of continual development and improvement. The installation methods described in this leaflet are not compulsory. The choice of KIMMCO materials and methods of fixing are the decision of the specifier, consultant or constructor. For further information or advice or specifications of KIMMCO products, contact your local office.